

# Worcester County Mathematics League

Varsity Meet 4

February 28, 2018

COACHES' COPY

ROUNDS, ANSWERS, AND SOLUTIONS

# WORCESTER COUNTY MATHEMATICS LEAGUE



## Varsity Meet 4 – February 28, 2018

### ANSWER KEY

#### Round 1:

1. 120 (Burncoat)
2. 15 and 21 (Tahanto)
3. 2309 (Tantasqua)

#### Round 2:

1.  $\frac{4}{3}$  or  $1\frac{1}{3}$  (Holy Name)
2. 9 feet and 2 inches (Worcester Academy)
3.  $3x+4y=-15$  or  $-3x-4y=15$  (Westborough)

#### Round 3:

1. (0, 10) (Southbridge)
2. 26 (Assabet)
3.  $4\pi$  (St. John's)

#### Round 4:

1. (10, 0) (Hudson)
2.  $\frac{7}{2}$  or  $3\frac{1}{2}$  or 3.5 (Tahanto)
3.  $\frac{2}{3}$  (St. John's)

#### Round 5:

1.  $\csc^2 x$  (Blackstone Valley)
2.  $\frac{3}{2}$  or  $1\frac{1}{2}$  or 1.5 (Shepherd Hill)
3. -3 (Assabet)

#### Team Round:

- |  |   |
|--|---|
| 1. $\frac{13}{6}$ or $2\frac{1}{6}$ or 2.167 (Lenhart) | 6. 553 (Assabet)                                  |
| 2. $\frac{7\pi}{10}$ (St. John's)                      | 7. -2 (Bartlett)                                  |
| 3. $-\frac{4}{17}$ or -0.235 (Shrewsbury)              | 8. $(2x^2y^2+xy+1)(2x^2y^2-xy+1)$ (Leicester)     |
| 4. 3y (Shepherd Hill)                                  | 9. <del>167,900</del> (Tahanto)<br><i>167,960</i> |
| 5. $40\sqrt{2}$ (Hopkinton)                            |   |

**WORCESTER COUNTY MATHEMATICS LEAGUE**



**Varsity Meet 4 – February 28, 2018**

**Round 1: Elementary Number Theory**

*All answers must be in simplest exact form in the answer section*

**NO CALCULATOR ALLOWED**

1. Given the numbers 280 and 525, what is the quotient of their least common multiple and greatest common factor?
2. Each of the numbers 1, 3, 6... are called triangular numbers because they represent the number of dots that can be arranged evenly in an equilateral triangle. In the sequence of triangular numbers, find 2 triangular numbers whose sum and difference are also triangular numbers.
3. Find the smallest counting number  $N$ , such that when  $N$  is divided by 2,3,5,6,7,11 the remainder is 1,2,4,5,6,10 respectively.

**ANSWERS**

(1 pt.) 1. \_\_\_\_\_

(2 pt.) 2. \_\_\_\_\_

(3 pt.) 3. \_\_\_\_\_

**WORCESTER COUNTY MATHEMATICS LEAGUE**



**Varsity Meet 4 – February 28, 2018**

**Round 2: Algebra 1 - OPEN**

*All answers must be in simplest exact form in the answer section*

**NO CALCULATOR ALLOWED**

1. Evaluate:

$$\frac{2^{-1}}{2^{-2} + 2^{-3}}$$

2. A plumber sends his assistant to the hardware store to buy a pipe that is  $x$  feet plus  $y$  inches long. The assistant buys a pipe  $y$  feet plus  $x$  inches long by mistake and returns with a pipe that is only  $\frac{3}{10}$  as long as the one the plumber needs. What is the smallest length the pipe that the plumber could have asked for?
3. Write the equation of the line which is perpendicular to the line  $4x - 3y = 6$  and which has the same  $x$ -intercept as the line  $3y - 2x = 10$ . Write your answer in the form  $ax + by = c$  where  $A, B, C \in J$ .

**ANSWERS**

(1 pt.) 1. \_\_\_\_\_

(2 pt.) 2. \_\_\_\_\_ feet and \_\_\_\_\_ inches

(3 pt.) 3. \_\_\_\_\_

**WORCESTER COUNTY MATHEMATICS LEAGUE**



**Varsity Meet 4 – February 28, 2018**

**Round 3: Geometry - OPEN**

*All answers must be in simplest exact form in the answer section*

**NO CALCULATOR ALLOWED**

4. If the slope of a line is  $-\frac{5}{3}$  and a point on the line is  $(3, 5)$ , what is the y-intercept?
5. Given the circle below with a chord length of 20, and the other distance marked as 2 cuts through the chord at its midpoint, find the radius of the circle.

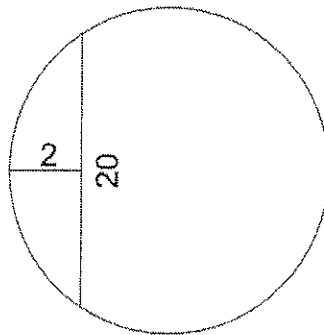

6. If the number of square units in the area of a regular triangle ABC equals the number of linear units in the circumference of its inscribed circle, find the exact perimeter of the triangle.

**ANSWERS**

(1 pt.) 1. ( \_\_\_\_\_, \_\_\_\_\_ )

(2 pt.) 2. \_\_\_\_\_

(3 pt.) 3. \_\_\_\_\_

**WORCESTER COUNTY MATHEMATICS LEAGUE**



**Varsity Meet 4 – February 28, 2018**

**Round 4: Logs, Exponents, Radicals**

*All answers must be in simplest exact form in the answer section*

**NO CALCULATOR ALLOWED**

1. Find the X - intercept of the graph of  $y=2 \log(\sqrt{x-1} -2)$

2. Find the sum of the solutions to:

$$2^{2x^2} * 2^{-7x} * 32 = 1$$

3. Solve given X is a real number:

$$4^{3x} + 2^{3x+2} = 32$$

**ANSWERS**

(1 pt.) 1. ( \_\_\_\_\_, \_\_\_\_\_ )

(2 pt.) 2. \_\_\_\_\_

(3 pt.) 3. \_\_\_\_\_

**WORCESTER COUNTY MATHEMATICS LEAGUE**



**Varsity Meet 4 – February 28, 2018**

**Round 5: Trigonometry - OPEN**

*All answers must be in simplest exact form in the answer section*

**NO CALCULATOR ALLOWED**

1. Express the following expression as a single trigonometric function:

$$\frac{(\tan x + \cot x)}{\tan x}$$

2. Evaluate and give your answer in simplest exact form:

$$\frac{\sec 180^\circ - \csc 90^\circ + \frac{1}{2} \cos(-240^\circ)}{-3 \sin(-330^\circ)}$$

3. If  $\cot(x + 45^\circ) = 2$  then  $\cot x = ?$

**ANSWERS**

(1 pt.) 1. \_\_\_\_\_

(2 pt.) 2. \_\_\_\_\_

(3 pt.) 3. \_\_\_\_\_



**Varsity Meet 4 – February 28, 2018**

**TEAM ROUND**

*All answers must either in simplest exact form or rounded to EXACTLY three decimal places, unless stated otherwise (2 points each).*

APPROVED CALCULATORS ALLOWED

1.  $xy - \frac{1}{6} = y - x = 3 - x - y$   
What is the value of  $x + y$ ?

2. Find the exact value of:  $\cot^{-1}\left(\tan\frac{4\pi}{5}\right)$

3. Evaluate, when  $a = -8$

$$\frac{2a^{-\frac{2}{3}}}{a^{-1} + a^{\frac{1}{3}}}$$

4. Divide and Simplify:

$$\frac{4x^2 - 25y^2}{2x^2y + 5xy^2} \div \frac{6x^2 - 15xy}{9x^2y^2}$$

5. Isosceles trapezoid ABCD has a mid-segment connecting the midpoint of  $\overline{AD}$ , which is E and the midpoint of  $\overline{BC}$ , which is F. Find the exact area of ABFE if  $AB=8$  and  $DC=16$  and  $AD=12$ .

6.  $\text{SUM } 222_{(3)} + 333_{(4)} + 444_{(5)}$   
Express your answer in base 6

7. Solve for x:

$$\frac{2}{3}(5x + 1) - \frac{3}{5}(2x - 1) = -3$$

8. Factor completely:

$$4x^4y^4 + 3x^2y^2 + 1$$

9. How many different ways can a 20 man baseball team have a starting line-up of 9 players?





**Varsity Meet 4 – SOLUTIONS**

**Round 1: Elementary Number Theory**

1. Given the numbers 280 and 525, what is the quotient of their least common multiple and greatest common factor?

Solution:

$$\text{GCF} = 35$$

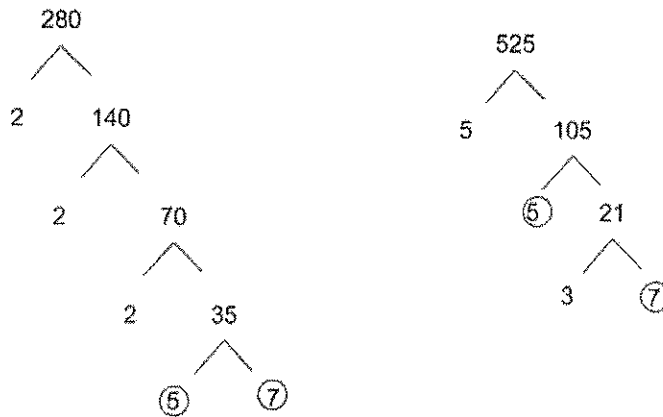

$$\text{LCM} = 4200$$

$$280 \times 15 = 4200$$

$$525 \times 8 = 4200$$

$$\text{Therefore } \frac{\text{LCM}}{\text{GCF}} = \frac{4200}{35} = 120$$

2. Each of the numbers 1, 3, 6... are called triangular numbers because they represent the number of dots that can be arranged evenly in an equilateral triangle. In the sequence of triangular numbers, find 2 triangular numbers whose sum and difference are also triangular numbers.

Solution:

$$T_n = \frac{n(n+1)}{2} \text{ where } n \text{ is the number of dots on each side of the triangle}$$

**WORCESTER COUNTY MATHEMATICS LEAGUE**



$$15 = \frac{5(5+1)}{2}$$

$$21 = \frac{6(6+1)}{2}$$

The difference between 21 and 15 is 6

$$6 = \frac{3(3+1)}{2}$$

The sum of 15 and 21 is 36

$$36 = \frac{8(8+1)}{2}$$

3. Find the smallest counting number  $N$ , such that when  $N$  is divided by 2, 3, 5, 6, 7, 11 the remainder is 1, 2, 4, 5, 6, 10 respectively.

**Solution:**

$$N = (2*3*5*7*11) - 1$$

$$= 2310 - 1$$

$$= 2309$$



Varsity Meet 4 – SOLUTIONS

Round 2: Algebra 1 - OPEN

1. Evaluate:

$$\frac{2^{-1}}{2^{-2} + 2^{-3}}$$

Solution:

$$\begin{aligned}\frac{2^{-1}}{2^{-2} + 2^{-3}} &= \frac{\frac{1}{2}}{\frac{1}{4} + \frac{1}{8}} \\ &= \frac{\frac{1}{2}}{\frac{2}{8} + \frac{1}{8}}\end{aligned}$$

$$\begin{aligned}\frac{1}{2} \div \frac{3}{8} &= \frac{1}{2} * \frac{8}{3} = \frac{8}{6} \\ &= \frac{4}{3} \text{ or } 1\frac{1}{3}\end{aligned}$$

2. A plumber sends his assistant to the hardware store to buy a pipe that is  $x$  feet plus  $y$  inches long. The assistant buys a pipe  $y$  feet plus  $x$  inches long by mistake and returns with a pipe that is only  $\frac{3}{10}$  as long as the one the plumber needs. What is the smallest length the pipe that the plumber could have asked for?

Solution:

The plumber needs a pipe  $12x + y$  inches long.

The assistant buys a pipe  $12y + x$  inches long.



$$12y + x = \frac{3}{10}(12x + y)$$

$$120y + 10x = 36x + 3y$$

$$117y = 26x$$

$$9y = 2x$$

Since this is the smallest integer solution, the plumber needs a pipe 9 feet and 2 inches long.

3. Write the equation of the line which is perpendicular to the line  $4x - 3y = 6$  and which has the same x-intercept as the line  $3y - 2x = 10$ . Write your answer in the form  $ax + by = c$  where  $A, B, C \in J$ .

Solution:

First, we'll find the x-intercept of  $3y - 2x = 10$ .

$$3(0) - 2x = 10$$

$$-2x = 10$$

$$x = -5$$

So the x-intercept is  $(-5, 0)$ .

Now, we'll find the slope of the line perpendicular to  $4x - 3y = 6$ . We'll begin by finding the slope of the line  $4x - 3y = 6$ .

$$4x - 3y = 6$$

$$3y = 4x - 6$$

$$y = \frac{4}{3}x - 2$$

The slope of  $4x - 3y = 6$  is  $\frac{4}{3}$ . The slope perpendicular to that line is the opposite reciprocal of the slope, so it is  $-\frac{3}{4}$ .

$$y - 0 = -\frac{3}{4}(x + 5)$$

$$4y = -3x - 15$$

So the answer is  $3x + 4y = -15$  or  $-3x - 4y = 15$ .



**Varsity Meet 4 – SOLUTIONS**

**Round 3: Geometry - OPEN**

1. If the slope of a line is  $-\frac{5}{3}$  and a point on the line is  $(3, 5)$ , what is the y-intercept?

**Solution:**

Point-slope form:  $y - y_1 = m(x - x_1)$

$$y - 5 = -\frac{5}{3}(x - 3)$$

$$y - 5 = -\frac{5}{3}x + 5$$

$$y = -\frac{5}{3}x + 10$$

The y-intercept is  $(0, 10)$ .

2. Given the circle below with a chord length of 20, and the other distance marked as 2 cuts through the chord at its midpoint, find the radius of the circle.

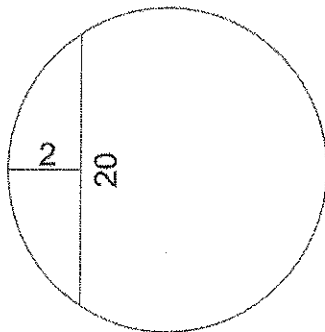

**Solution:**

$$10 * 10 = 2(d - 2)$$

$$100 = 2d - 4$$

$$104 = 2d$$

$$d = 52$$



$r = 26$

3. If the number of square units in the area of a regular triangle ABC equals the number of linear units in the circumference of its inscribed circle, find the exact perimeter of the triangle.

Solution:

Using the apothem:

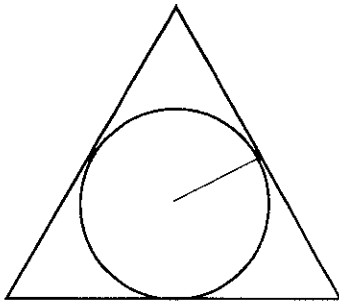

$$area = \frac{1}{2}ap = \frac{r}{2}(a + b + c) = 2\pi r$$

$$a + b + c = 4\pi$$

Answer:  $4\pi$



Varsity Meet 4 – SOLUTIONS

Round 4: Logs, Exponents, Radicals

1. Find the X - intercept of the graph of  $y=2 \log(\sqrt{x-1} -2)$

$$y=2\log(\sqrt{x-1} -2)$$

$$0=2\log(\sqrt{x-1} -2)$$

$$0=\log(\sqrt{x-1} -2)$$

$$\log 1 = (\sqrt{x-1} -2)$$

$$1 = \sqrt{x-1} -2$$

$$3 = \sqrt{x-1}$$

$$9 = x - 1$$

$$x = 10$$

$$(10, 0)$$

Solution:

2. Find the sum of the solutions to:

$$2^{2x^2} * 2^{-7x} * 32 = 1$$

$$2^{2x^2} * 2^{-7x} * 2^5 = 2^0$$

$$2^{2x^2-7x+5} = 2^0$$

$$2x^2 - 7x + 5 = 0$$

$$(2x - 5)(x - 1) = 0$$

$$x = \frac{5}{2} \text{ or } x = 1$$

$$\frac{5}{2} + 1 = \frac{7}{2} \text{ or } 3\frac{1}{2} \text{ or } 3.5$$



3. Solve given X is a real number:

$$4^{3x} + 2^{3x+2} = 32$$

Solution:

$$4^{3x} + 2^{3x+2} = 32$$

$$2^{6x} + 2^{3x+2} = 2^5$$

$$(2^{3x})^2 + 4(2^{3x}) - 32 = 0$$

$$(y + 8)(y - 4) = 0$$

$$2^{3x} = 8$$

$$2^{3x} = 4$$

$$2^{3x} = 2^2$$

$$3x = 2$$

$$\text{Ans. } x = \frac{2}{3}$$



WORCESTER COUNTY MATHEMATICS LEAGUE



Varsity Meet 4 – SOLUTIONS  
Round 5: Trigonometry - OPEN

1. Express the following expression as a single trigonometric function:

$$\frac{(\tan x + \cot x)}{\tan x}$$

Solution:

$$\frac{\tan x + \cot x}{\tan x}$$

$$\tan x + \cot x = \sec x * \csc x$$

$$\frac{\sec x * \csc x}{\tan x}$$

$$\frac{\sec x}{\tan x} = \csc x$$

$$\csc x * \csc x$$

$$\text{Answer} = \csc^2 x$$

2. Evaluate and give your answer in simplest exact form:

$$\frac{\sec 180^\circ - \csc 90^\circ + \frac{1}{2} \cos(-240^\circ)}{-3 \sin(-330^\circ)}$$

Solution:

WORCESTER COUNTY MATHEMATICS LEAGUE



$$\frac{\sec 180^\circ - \csc 90^\circ + \frac{1}{2} \cos(-240^\circ)}{-3 \sin(-330^\circ)}$$

$$\frac{-1 - 1 + \left(-\frac{1}{2}\right)\left(\frac{1}{2}\right)}{(+3)\left(-\frac{1}{2}\right)}$$

$$\frac{-2 + \frac{-1}{4}}{\frac{-3}{2}} = \frac{-9}{4} * \frac{-2}{3} = \frac{3}{2} \text{ or } 1\frac{1}{2} \text{ or } 1.5$$

3. If  $\cot(x + 45^\circ) = 2$  then  $\cot x = ?$

Solution:

$$\frac{\cos(x + 45)}{\sin(x + 45)} = \frac{\cos * \cos 45 - \sin * \sin 45}{\sin * \cos 45 + \sin 45 \cos x} = 2$$

$$\frac{\cos x * \frac{\sqrt{2}}{2} - \sin x * \frac{\sqrt{2}}{2}}{\sin x * \frac{\sqrt{2}}{2} + \cos x * \frac{\sqrt{2}}{2}} = \frac{2}{1} \rightarrow \frac{\cos x - \sin x}{\sin x + \cos x} = \frac{2}{1}$$

$$\cos x - \sin x = 2 \sin x + 2 \cos x$$

$$3 \sin x = \cos x$$

$$-3 = \cot x$$



Varsity Meet 4 – SOLUTIONS

TEAM ROUND

1.  $xy - \frac{1}{6} = y - x = 3 - x - y$

What is the value of  $x + y$ ?

Solution:

If  $y - x = 3 - x - y$  then  $y = 3 - y$  and  $y = \frac{3}{2}$

Since  $xy - \frac{1}{6} = y - x$ , we have  $(\frac{3}{2})x - \frac{1}{6} = \frac{3}{2} - x$

$\rightarrow 5x - \frac{1}{3} = 3 \rightarrow x = \frac{2}{3}$  therefore  $x + y = \frac{13}{6}$  or  $2\frac{1}{6}$  or 2.167

2. Find the exact value of:  $\cot^{-1}\left(\tan\frac{4\pi}{5}\right)$

Solution:

$$\cot^{-1}(x) = \frac{\pi}{2} - \tan^{-1}(x)$$

$$\cot^{-1}\left(\tan\frac{4\pi}{5}\right) = \frac{\pi}{2} - \tan^{-1}\left(\tan\frac{4\pi}{5}\right)$$

$$\frac{\pi}{2} - \left(-\frac{\pi}{5}\right) = \frac{7\pi}{10}$$

3. Evaluate, when  $a = -8$

$$\frac{2a^{-\frac{2}{3}}}{a^{-1} + a^{\frac{1}{3}}}$$

Solution:

$$\frac{2(-8)^{-2/3}}{(-8)^{-1} + (-8)^{1/3}} = \frac{2\left(\frac{1}{4}\right)}{-\frac{1}{8} + (-2)}$$

**WORCESTER COUNTY MATHEMATICS LEAGUE**



$$= \frac{1}{2} * \frac{8}{17} = -\frac{4}{17} \text{ or } -0.235$$

4. Divide and Simplify:

$$\frac{4x^2 - 25y^2}{2x^2y + 5xy^2} \div \frac{6x^2 - 15xy}{9x^2y^2}$$

Solution:

$$\frac{(2x + 5y)(2x - 5y)}{xy(2x + 5y)} * \frac{3^3 9x^2y^2}{3x(2x - 5y)}$$

Answer =  $3y$

5. Isosceles trapezoid ABCD has a mid-segment connecting the midpoint of  $\overline{AD}$ , which is E and the midpoint of  $\overline{BC}$ , which is F. Find the exact area of ABFE if AB = 8 and DC = 16 and AD = 12.

Solution:

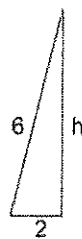
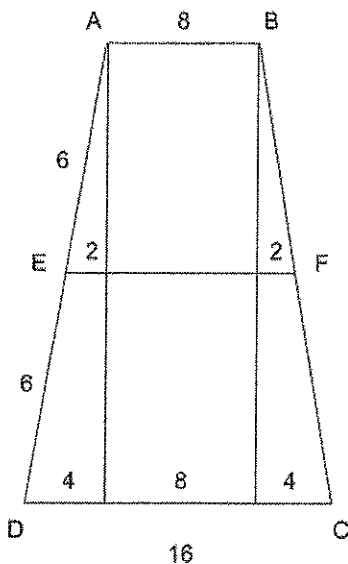

$$\text{midseg} = 12$$

$$2^2 + h^2 = 6^2$$

$$6^2 = 32$$

$$h = 4\sqrt{2}$$

$$A_{ABFE} = \frac{1}{2} (4\sqrt{2})(12 + 8)$$

$$= 40\sqrt{2}$$

WORCESTER COUNTY MATHEMATICS LEAGUE



6. SUM  $222_{(3)} + 333_{(4)} + 444_{(5)}$   
Express your answer in base 6

Solution:

$$222_{(3)} = 2 + 6 + 18 = 26_{(10)}$$

$$333_{(4)} = 3 + 12 + 48 = 63_{(10)}$$

$$444_{(5)} = 4 + 20 + 100 = 124_{(10)}$$

$$26 + 63 + 124 = 213_{(10)}$$

$$213 / 6 = 35 \text{ R}3$$

$$35 / 6 = 5 \text{ R}5$$

$$5 / 6 = 0 \text{ R}5$$

$$213_{(10)} = 553_{(6)}$$

7. Solve for x:

$$\frac{2}{3}(5x + 1) - \frac{3}{5}(2x - 1) = -3$$

Solution:

$$\frac{2}{3}(5x + 1) - \frac{3}{5}(2x - 1) = -3$$

$$10(5x + 1) - 9(2x - 1) = -45$$

$$50x + 10 - 18x + 9 = -45$$

$$32x + 19 = -45$$

$$32x = -64$$

$$x = -2$$

8. Factor completely:

$$4x^4y^4 + 3x^2y^2 + 1$$

WORCESTER COUNTY MATHEMATICS LEAGUE



Solution: Add and subtract  $x^2y^2$

$$\frac{4x^4y^4 + 3x^2y^2 + 1 + x^2y^2 - x^2y^2}{(2x^2y^2 + 1)^2 - (xy)^2}$$
$$(2x^2y^2 + xy + 1)(2x^2y^2 - xy + 1)$$

9. How many different ways can a 20 man baseball team have a starting line-up of 9 players?

Solution:

$$20^c_9 = \frac{20 * 19 * 18 * 17 * 16 * 15 * 14 * 13 * 12}{9!}$$
$$= \del{167,900}$$
$$= 167,960$$